

## Assembly & Installation

### CS Cavity Slider™ Kitset Pocket Frame

Watch  
Video:



### Tools Required - Assembly

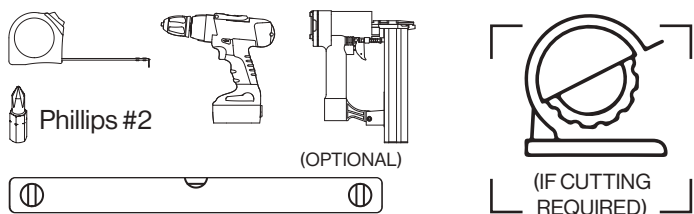

#8 screws and appropriate anchors required for installation

### Tools Required - Trim Fitting

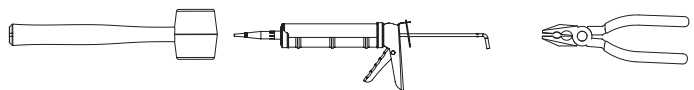

### Safety Gear Required



### Parts List

\*for CS Ultimate Only

- Corner Joining Bracket (8)
- Split Jamb Joining Bracket (4)
- Slat Joining Bracket (12) (16)\*
- #8 x 33/64" (13mm) Self Drilling Gold Plate (32) (40)\*
- #10 x 35/64" (14mm) Self Tapping Zinc Plate (36) (40)\*
- 1/4 Crown x 3/8 Leg" 18-Gauge Finish Staple (32)
- Foam Stop (2)
- Bi-Parting Pin
- T-Guide Base
- Block Clip (12)
- Short T-Guide
- Trim Clip (16)
- Long T-Guide
- CS Ultimate Setting Block - Used for:  
- Spreading & holding jambs in place  
for 2x6 stud size frame
- Setting Block - Used for:  
- Positioning soft close activator  
- Spreading & holding jambs in place  
for 2x4 stud size frame



Dimensions below suit 3/4"  
(19mm) jamb thickness

DW = Door Width DH = Door Height

If cutting the Track **C** ensure you do **not** cut the notched end

<b>A</b>	Back Stud x1		DH + 2 7/8" (DH + 74mm)
<b>B</b>	Split Jamb x2	<i>Door size: 2'0" x 6'8" to 3'0" x 6'8"</i>	DH + 2 11/16" (DH + 68mm)
<b>B</b>	Split Jamb x2	<i>Door size: 2'0" x 8'0" to 5'0" x 10'0"</i>	DH + 2 11/16" (DH + 68mm)
<b>C</b>	Track x1	<b>ULTIMATE</b>	DW x 2
<b>D</b>	Bottom Plate x1	<b>ULTIMATE</b>	DW - 1/8" (DW - 3mm)
<b>E</b>	Slat x6	<i>Door size: 2'0" x 6'8" to 3'0" x 6'8"</i>	DW - 4" (DW - 101.5mm)
<b>E</b>	Slat x6 (x8)*	<i>Door size: 2'0" x 8'0" to 5'0" x 10'0"</i> *for 9'0 & 10'0 Ultimate Frame	DW - 5 9/16" (DW - 141.5mm)
<b>F</b>	Top Fixing Block x2		DW + 1/8" (DW + 3mm)
<b>G</b>	Bottom Fixing Block x2	<i>Door size: 2'0" x 6'8" to 3'0" x 6'8"</i>	DW - 7 1/2" (DW - 190mm)
<b>G</b>	Bottom Fixing Block x2	<i>Door size: 2'0" x 8'0" to 4'0" x 8'0"</i>	DW - 9" (DW - 230mm)

### Rough Opening (RO)

Dimension	inches	mm
RO height (ROH)	DH + 4 1/4"	DH + 108
RO width - Single	(DW x 2) + 2"	(DWx2) + 51
RO width - Bi-Parting	(DW x 4) + 2"	(DWx4) + 51

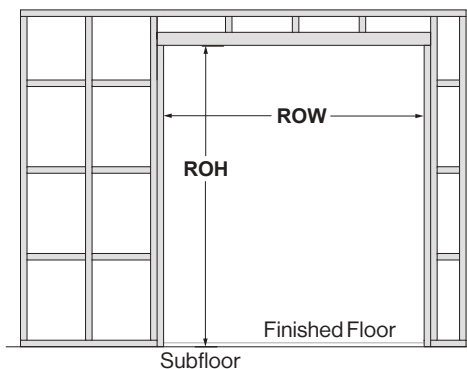

**Assembly**

**1.**

**B** x 2

2'0" x 8'0" to 4'0" x 8'0"

2'0" x 6'8" to 3'0" x 6'8"

**E** x 4

#8 x 33/64" (13mm)  
Self Drilling Gold Plated  
x 8

(or staples)

**2.**

**E** x 6

x 12

#8 x 33/64" (13mm)  
Self Drilling  
Gold Plated  
x 24

(or staples)

**3.**

**C**

**ULTIMATE**

Notched end

#10 x 35/64" (14mm)  
Self Tapping  
Zinc Plated  
x 2

**A**

**ULTIMATE**

**4.**

**D**

**ULTIMATE**

**G**

Slide

**5.**

#10 x 35/64" (14mm)  
Self Tapping  
Zinc Plated  
x 2

**6.**

**B**

**DO NOT FASTEN!**  
(until step 9)

Assembly

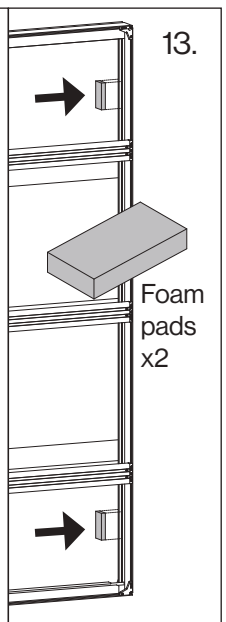
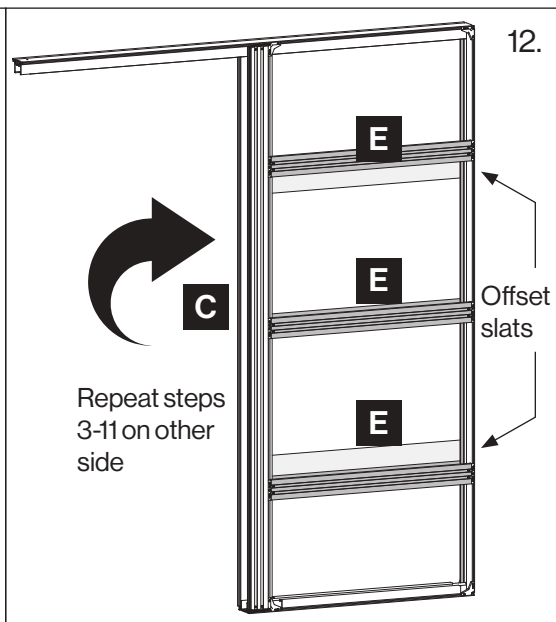
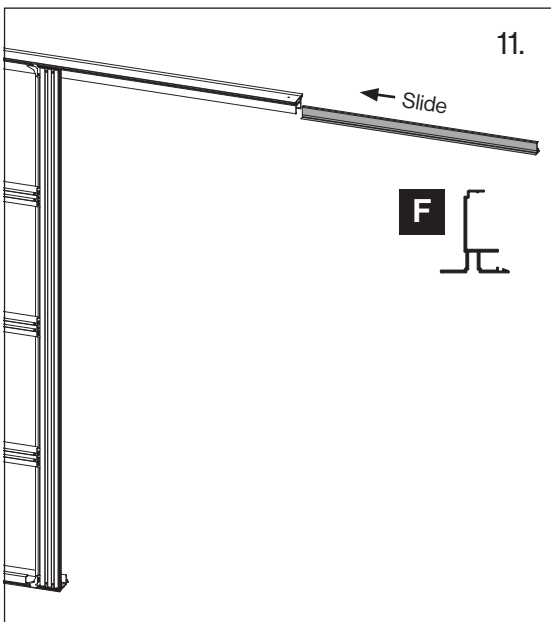
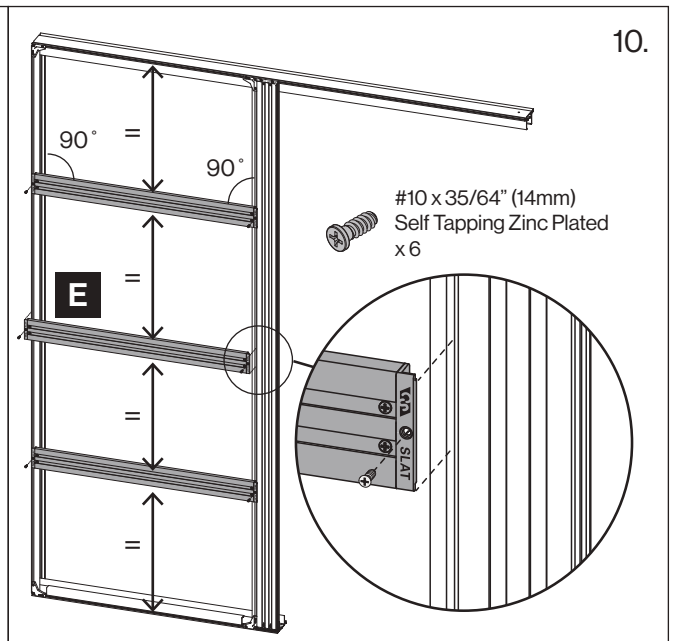
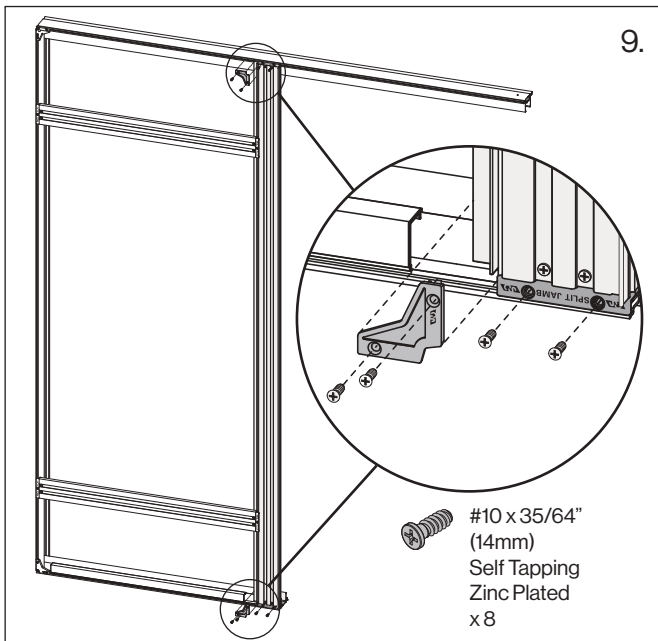
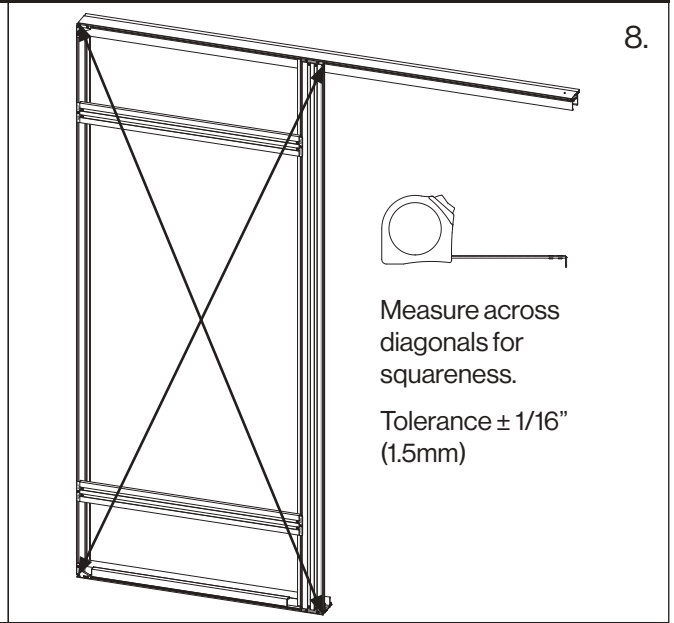
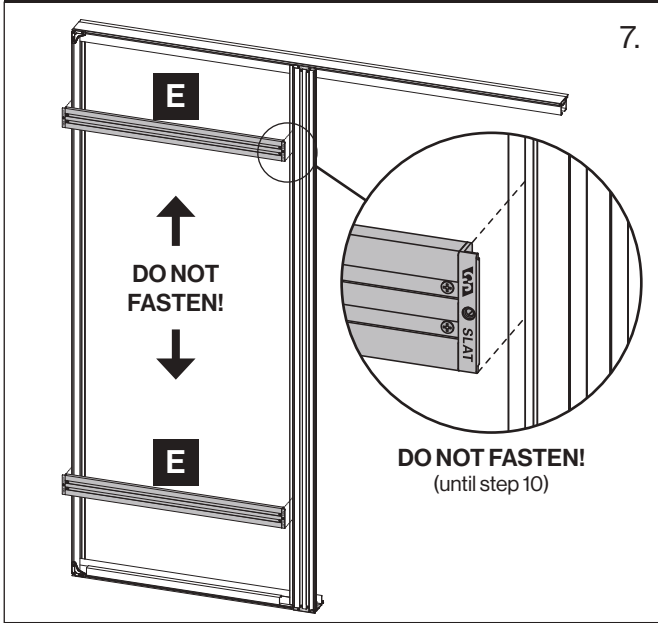

Assembly

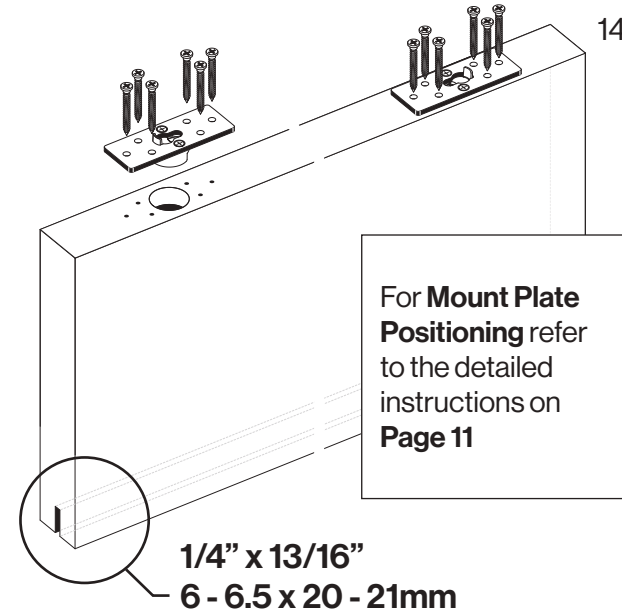
14. 

For **Mount Plate Positioning** refer to the detailed instructions on **Page 11**

**1/4" x 13/16"**  
**6 - 6.5 x 20 - 21mm**

15. **Select T-Guide based on flooring thickness** 15.

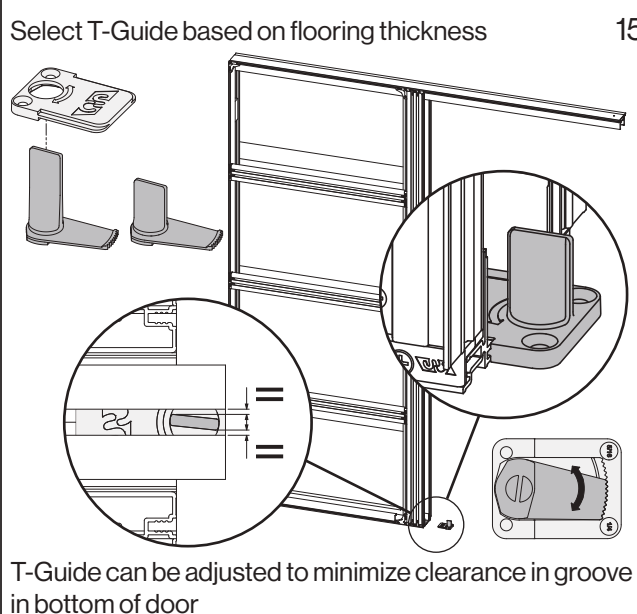

T-Guide can be adjusted to minimize clearance in groove in bottom of door

16. **Standard M6/M8 (non-SofStop)** 17A

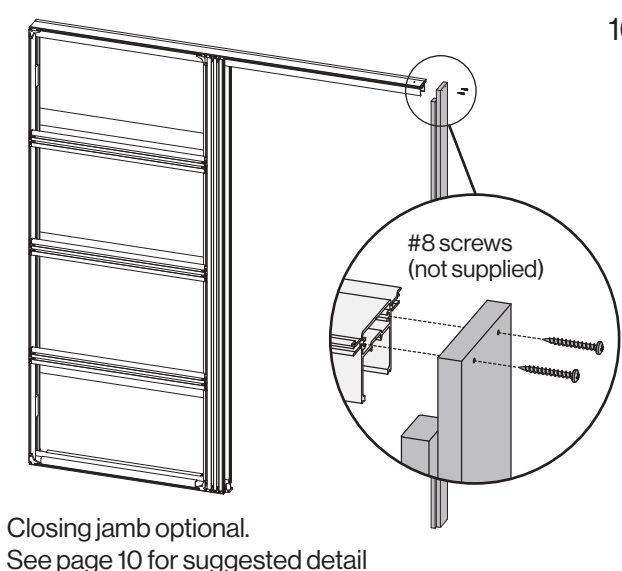

#8 screws (not supplied)

Closing jamb optional.  
See page 10 for suggested detail

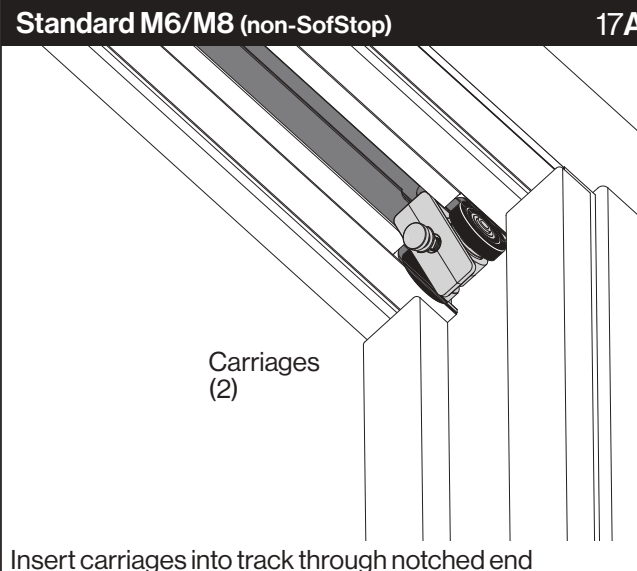

Carriages (2)

Insert carriages into track through notched end

**SofStop® Single (Soft Close)** 17B

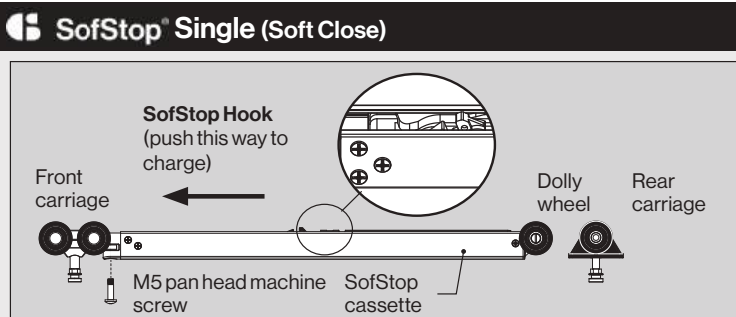

SofStop Hook (push this way to charge)

Front carriage      M5 pan head machine screw      SofStop cassette      Dolly wheel      Rear carriage

a) Single SofStop mechanism fits together as shown above.  
**Push the hook in direction shown to charge the mechanism.**

**ATTENTION: CHECK YOUR MECHANISM**

Your mechanism should have one of the following codes on its label: **ZK00505 OR ZK00506**

If it does **not**, please scan the QR code to view the correct instructions



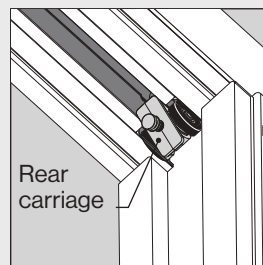

b) Insert rear carriage

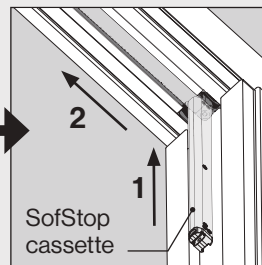

c) Insert cassette

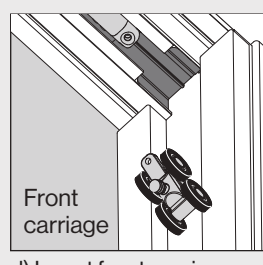

d) Insert front carriage

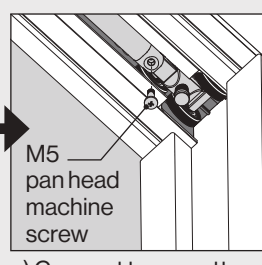

e) Connect to cassette

**DO NOT DRYWALL THE POCKET UNTIL THE SOFSTOP MECHANISM HAS BEEN INSTALLED & TESTED.**

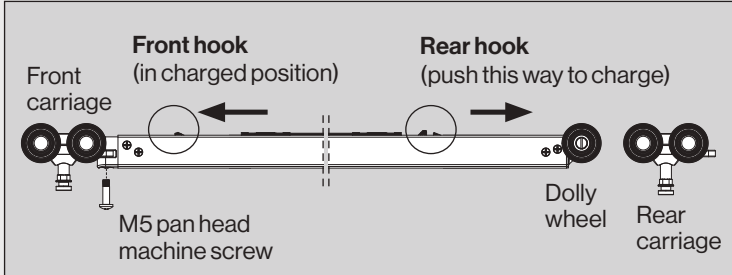

a) The twin SofStop mechanism fits together as shown above. **Push front and rear hook in the direction shown to charge the mechanism.**

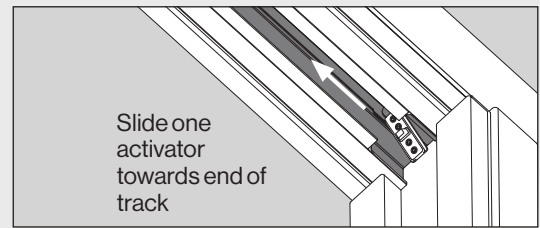

b) Insert one activator into track notch and slide towards end of track. **Do not tighten screws - this position is temporary.**

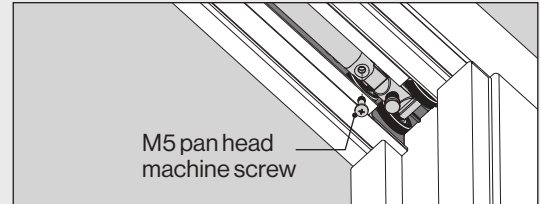

c) Insert rear carriage, cassette and front carriage using same method as Single Sofstop (17B). Secure carriage to cassette.

**Watch Video:** SofStop Installation and Trouble Shooting Tips

**Installation**

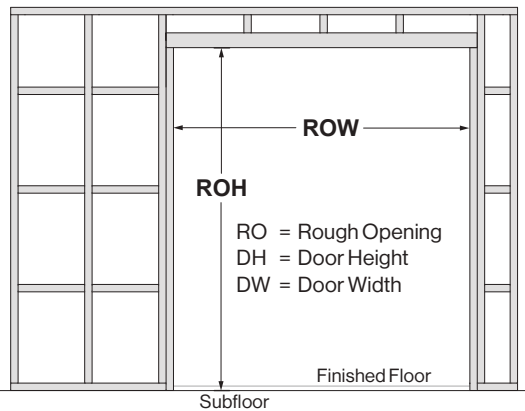

Dimension	inches	mm
RO height (ROH)	DH + 4¼"	DH + 108
RO width - Single	(DW x 2) + 2"	(DWx2) + 51
RO width - Bi-Parting	(DW x 4) + 2"	(DWx4) + 51

**Hang the door.**

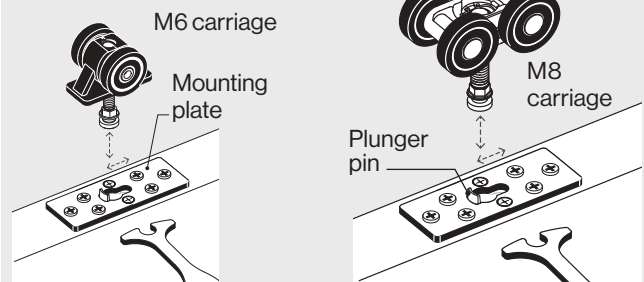

Position carriages in track above the door opening. Slide door over T-Guide. Raise door up so that hanger shaft lines up with hole in mounting plate. Depress plunger using wheel hanger shaft head and slide sideways using adjusting wrench until it snaps into locked position. Repeat for the other carriage.

**If you do not have your door at time of frame installation, we suggest hanging a dummy door of the same size to ensure the frame is plumb, level & square**

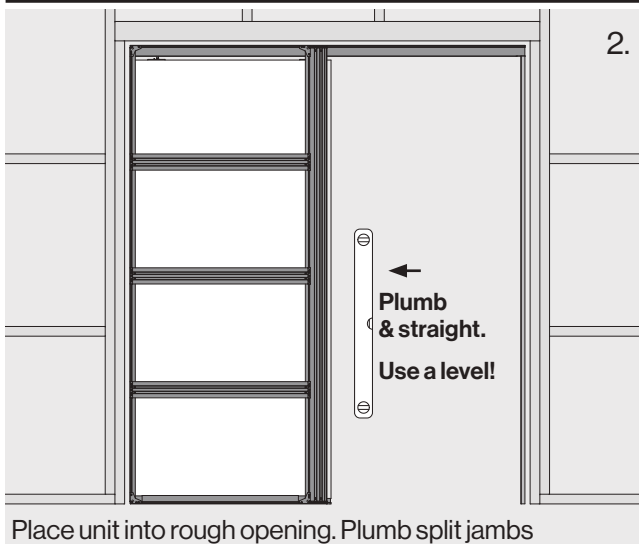

Place unit into rough opening. Plumb split jambs

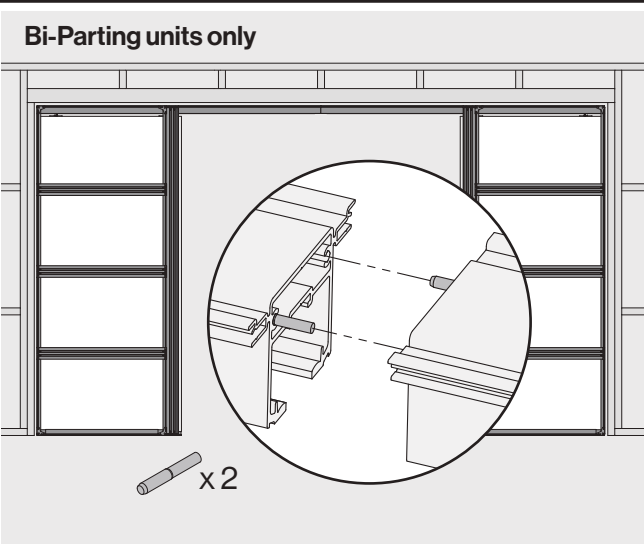

# Installation

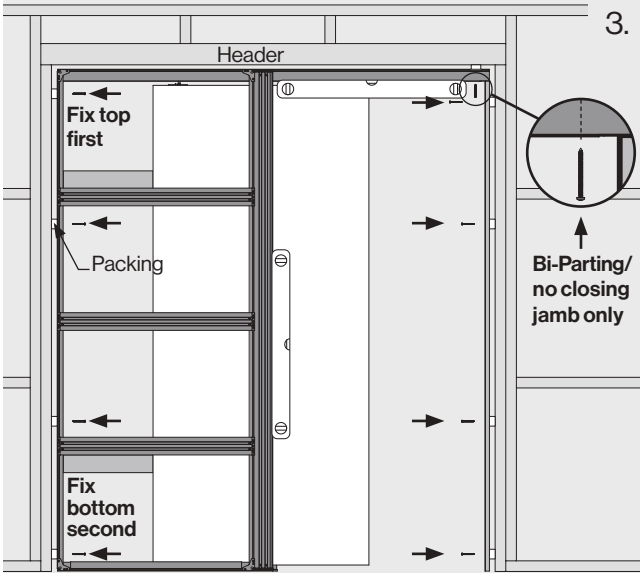

3.

Bi-Parting/  
no closing  
jamb only

Keep plumb and pack where required.  
Fix back stud and closing jamb (if using) with #8 countersunk screws (not supplied).  
Bi-Parting units or units with no closing jamb need to be fixed to the header through the pre drilled hole, otherwise **DO NOT** fix through the track.

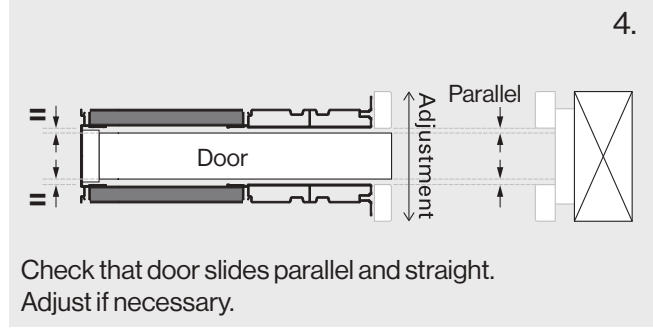

4.

Check that door slides parallel and straight.  
Adjust if necessary.

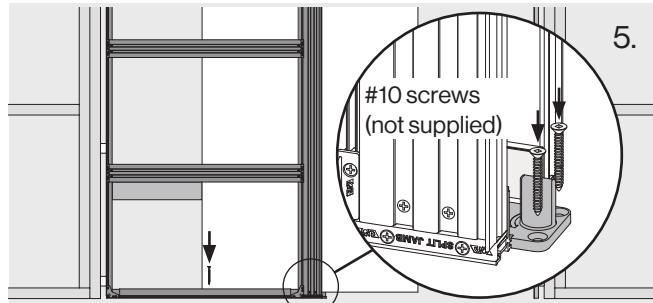

5.

#8 screw or appropriate anchor (not supplied)

Securely fix T-Guide then bottom plate to floor

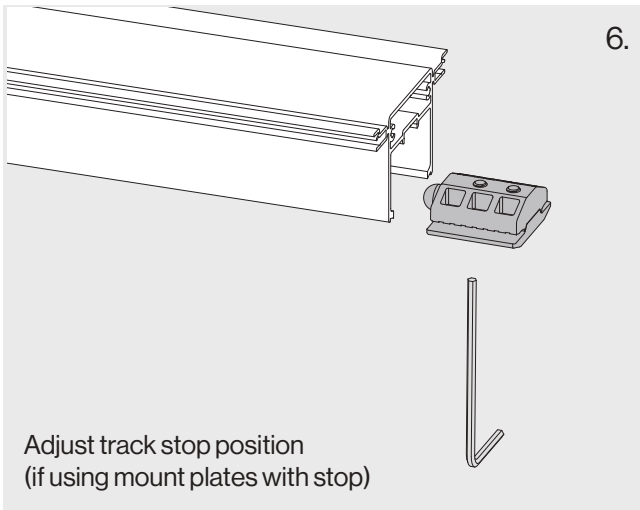

6.

Adjust track stop position  
(if using mount plates with stop)

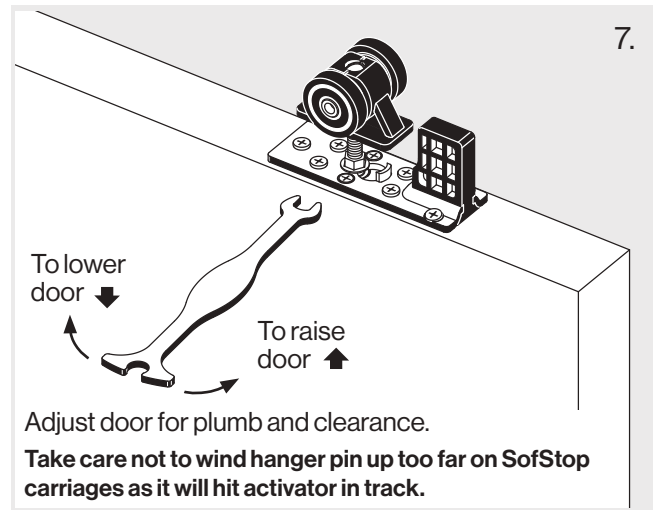

7.

Adjust door for plumb and clearance.  
**Take care not to wind hanger pin up too far on SofStop carriages as it will hit activator in track.**

## SofStop® Single & Twin

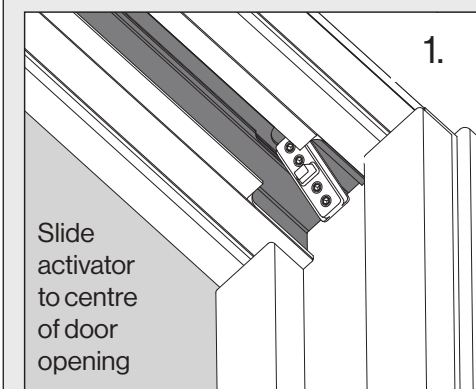

1.

Slide activator to centre of door opening

Set front activator position.

Orient the activator setting block according to your SofStop model (SofStop or SofStop HD) per the diagram below.

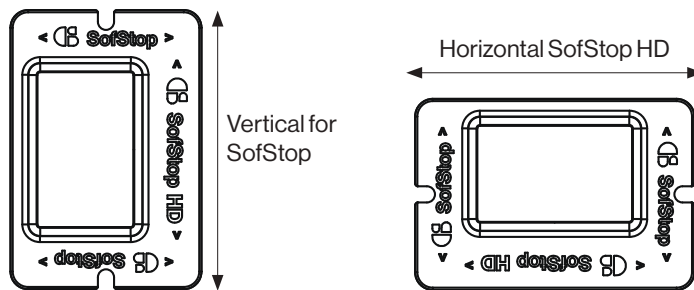

**SofStop® Single & Twin**

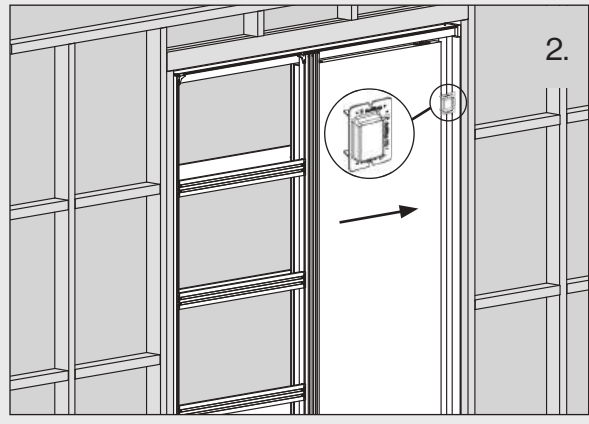

Hold setting block on closing jamb/finished wall and gently close door. Activator will slide to correct position. Securely tighten set screws on activator.

**Bi-Parting Pair**

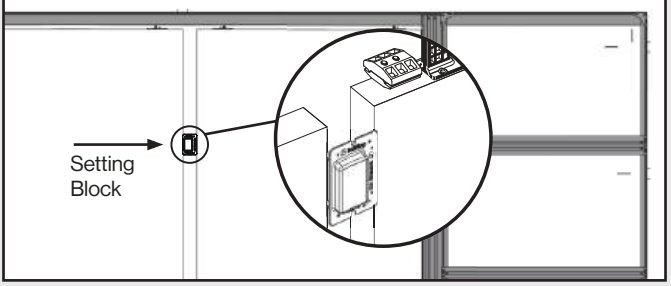

**Mounting Plate with Stop:** Hang one door of the bi-parting pair and set one track stop in position so that this door meets the center-line of the opening in its closed position. Use the front edge of this door as the closing jamb to set the front activator on the second door. Position the track stop for the second door and repeat on the other side.

**WARNING:** If the door soft closes, but does not come to a stand still on a strike jamb, closing jamb or track stop, you risk breaking the hook on the soft close mechanism. If you use the activator setting block correctly this will be avoided.

**SofStop® Twin ONLY**

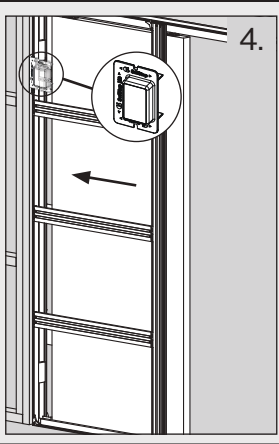

**4. Set rear activator position**  
Close door and move rear activator into centre of the pocket. **Do not tighten set screws.**  
Position setting block against the back stop cushion and gently open door onto it. Activator will slide along track into correct position.  
Rear activator is now positioned. Securely tighten all four set screws.

**Trim**

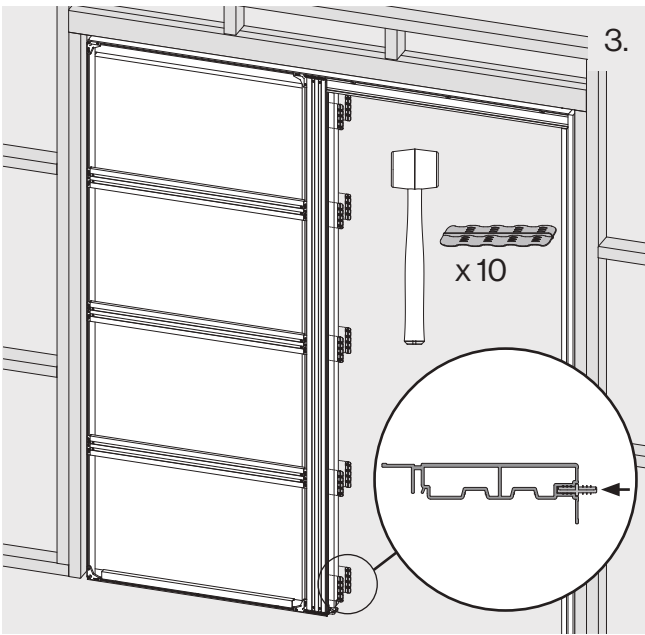
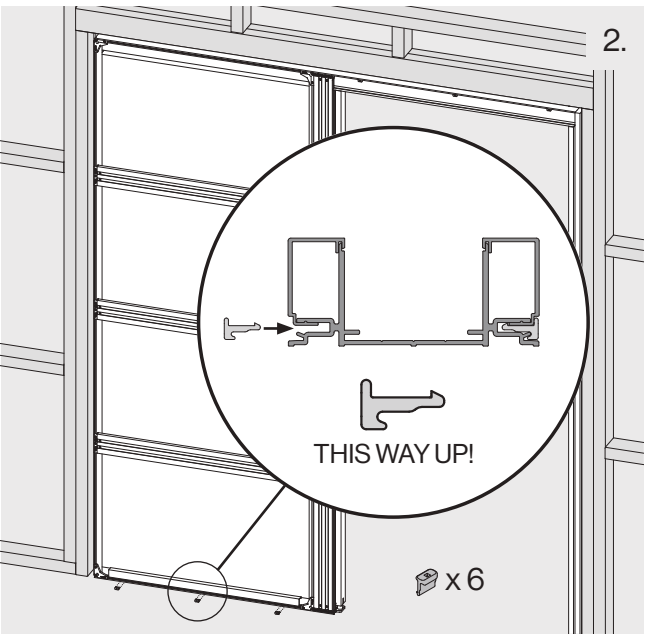
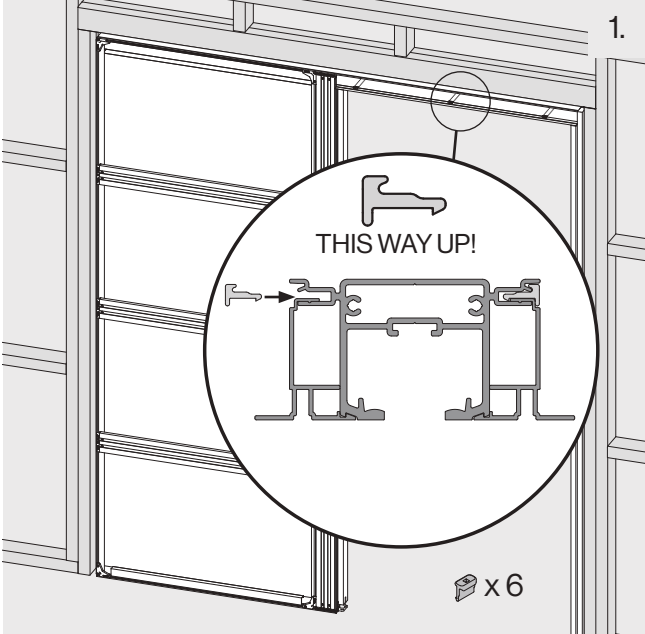

Trim/Finishing

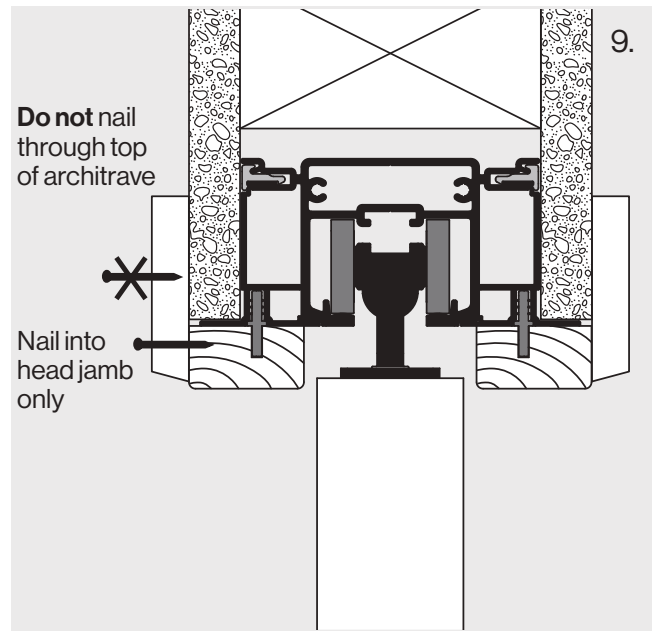
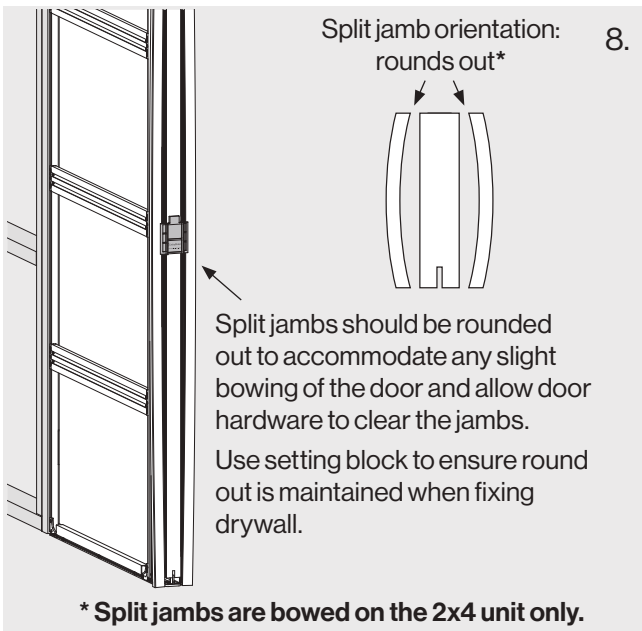
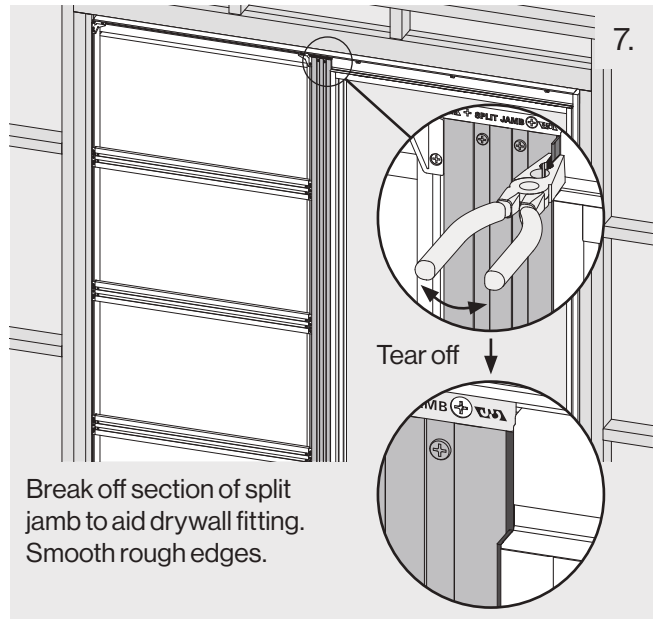
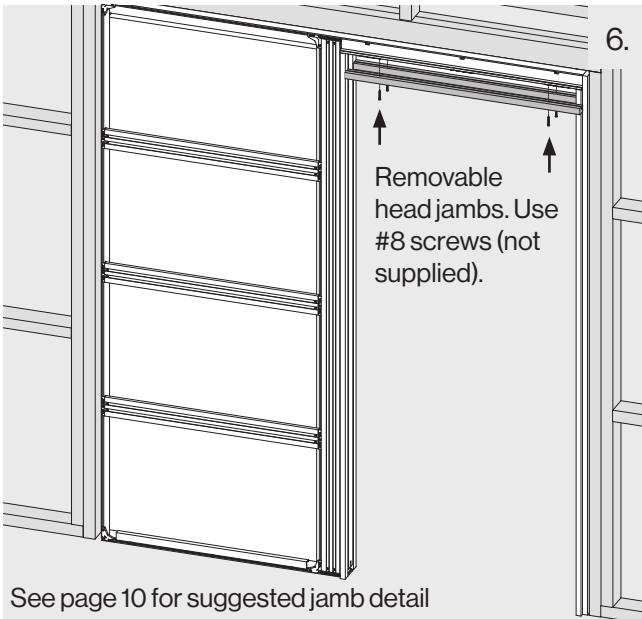
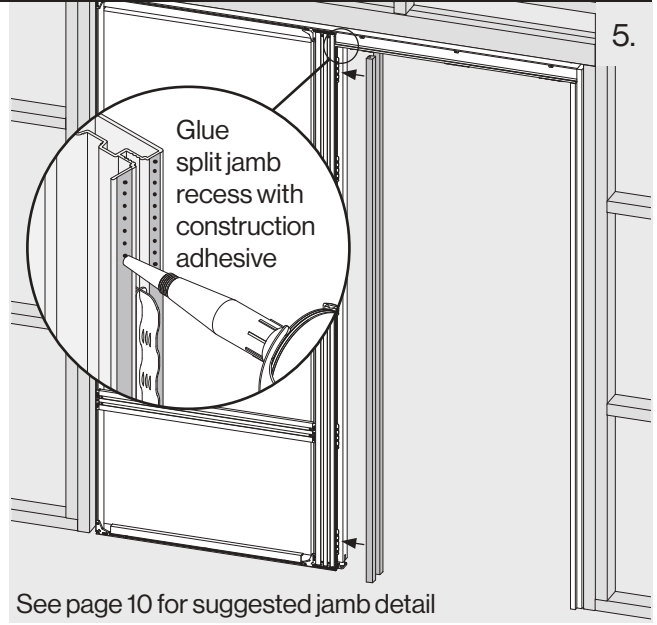
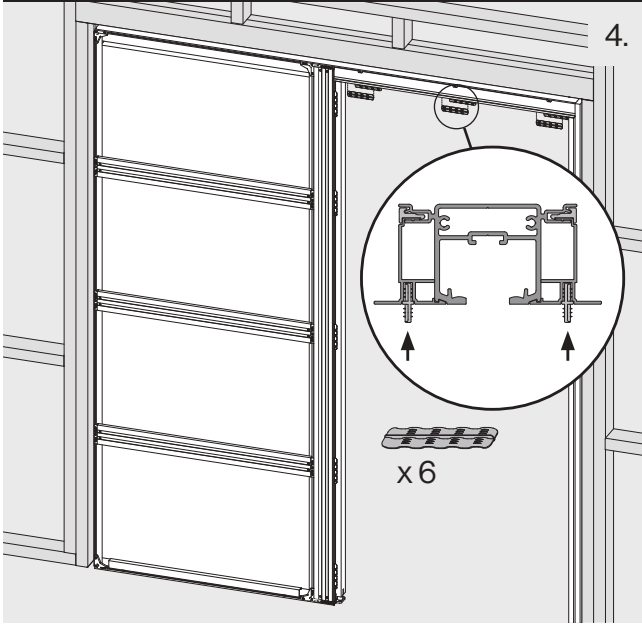

### Trim/Finishing

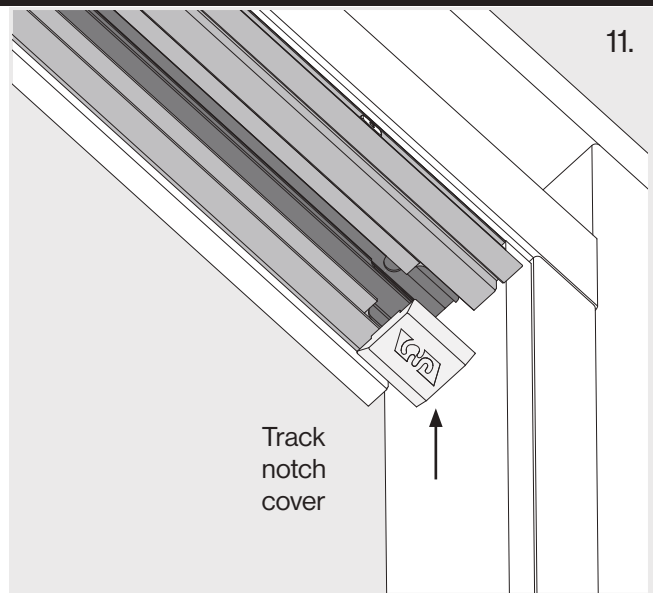
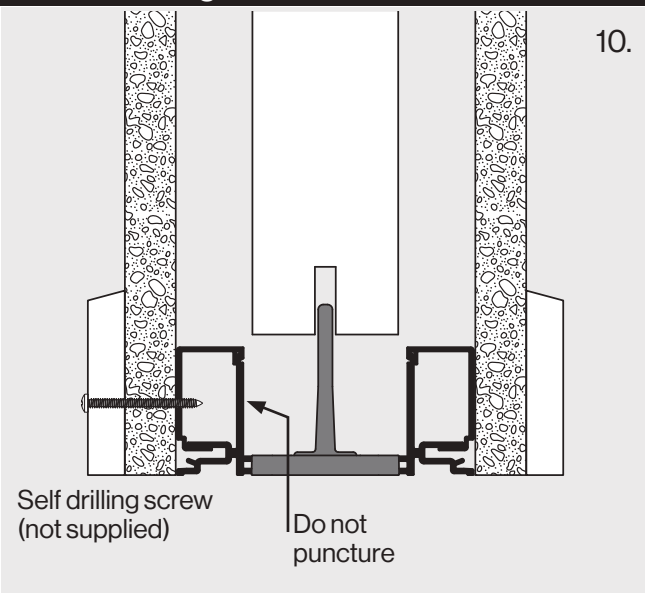

### Removing Door

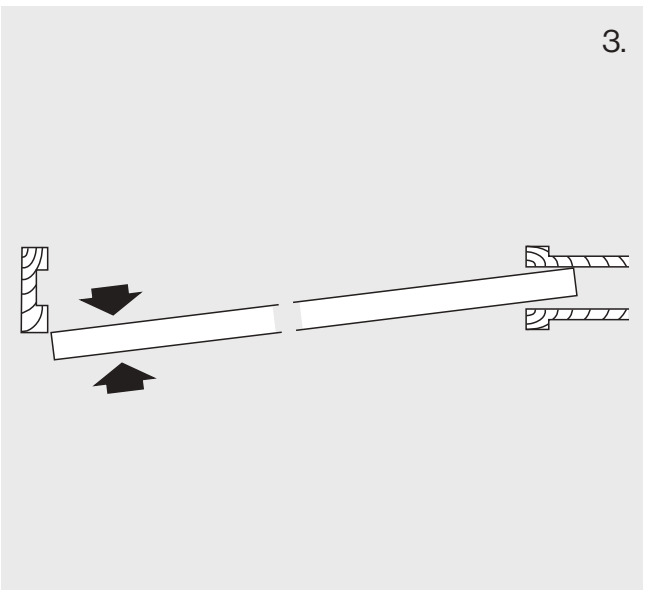
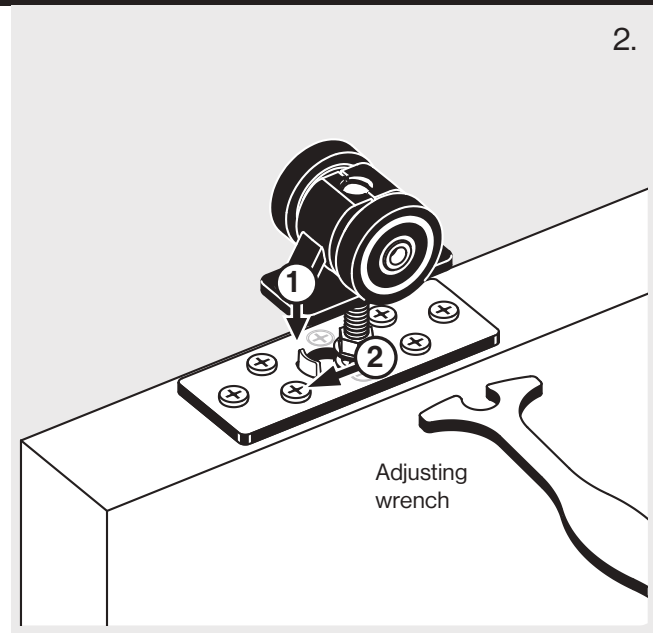
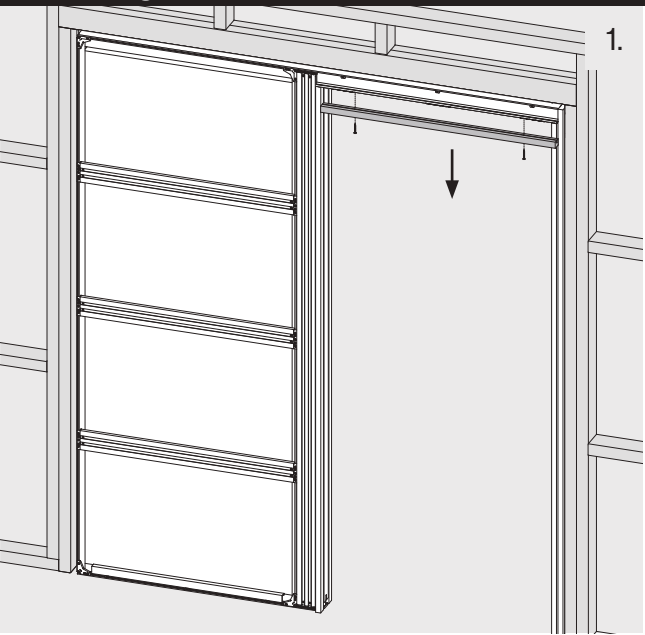

Details for  
**2x4**  
 frame  
 1 3/4"  
 doors

### Head Jamb (removable)

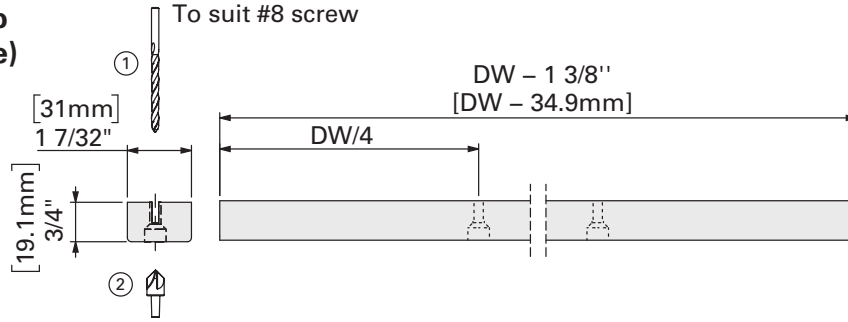

### Split Jambs & Head Jambs

(1 3/4" Door with 1/2" Drywall and 2x4 stud)

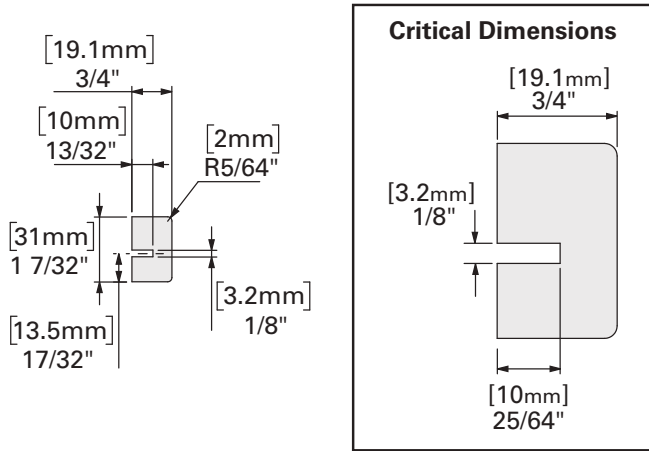

### Closing Jamb

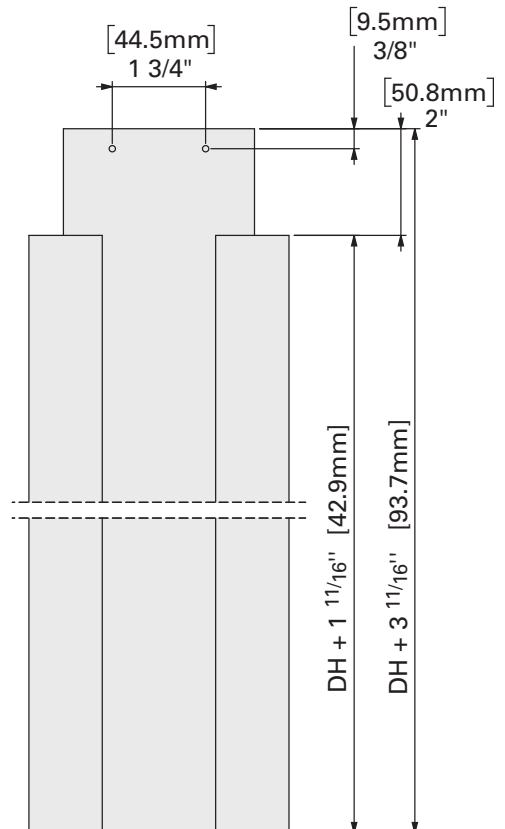
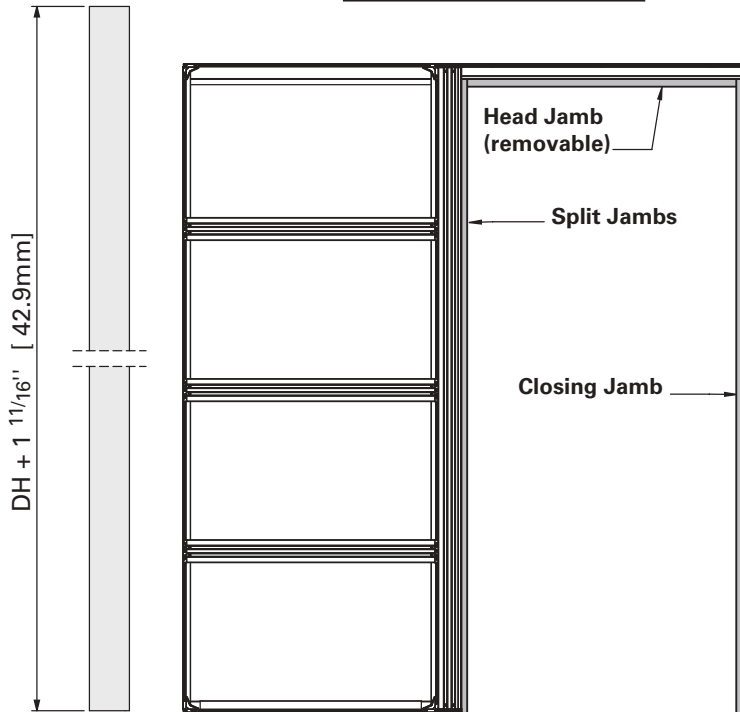
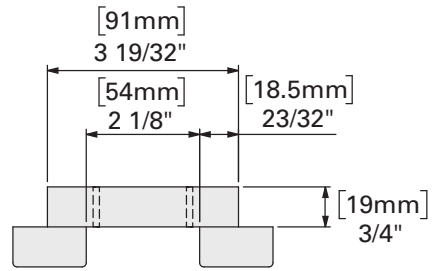

Details for  
**2x6**  
frame  
**1 3/4"**  
doors

**Head Jamb (removable)**

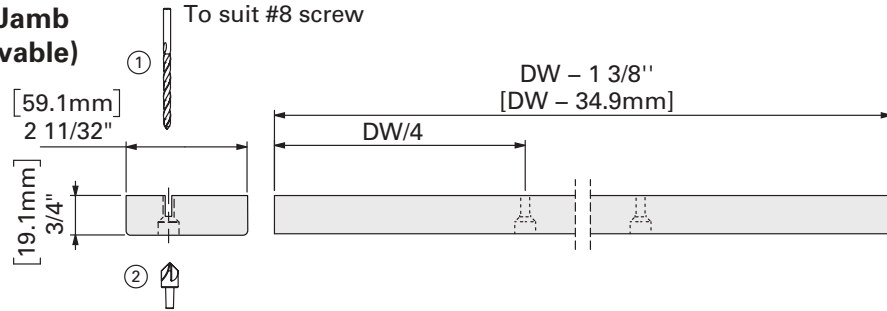

**Split Jambs & Head Jambs**

(1 3/4" Door with 5/8" Drywall and 2x6 stud)

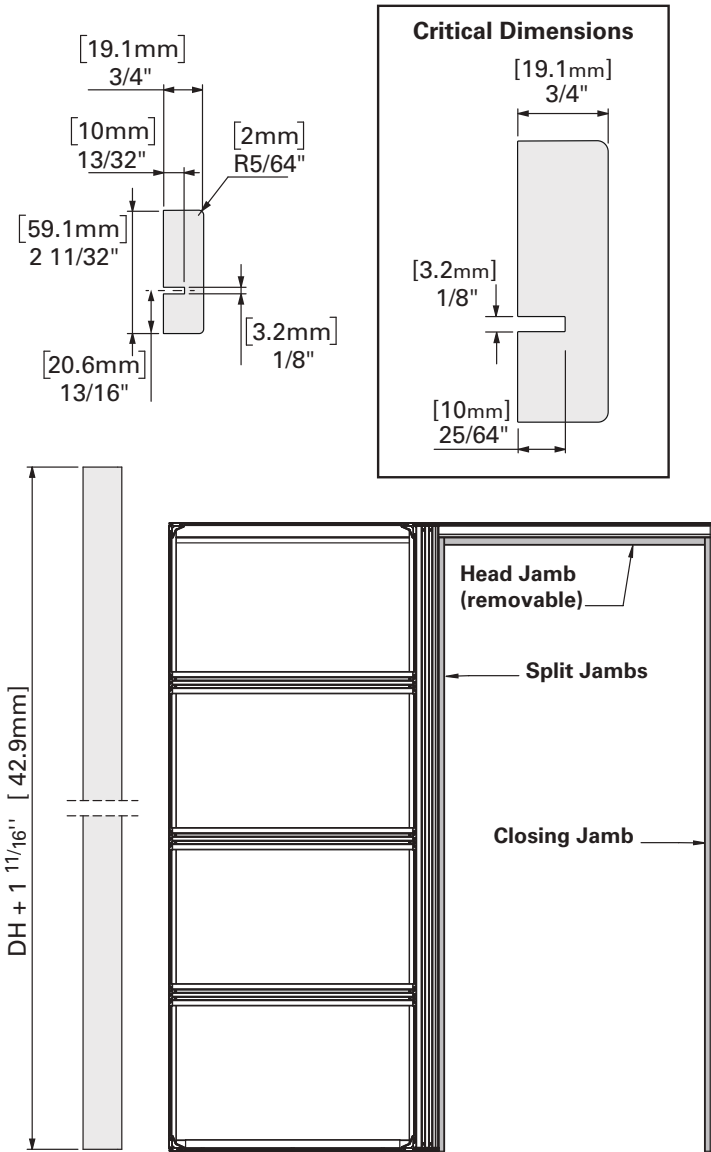

**Closing Jamb**

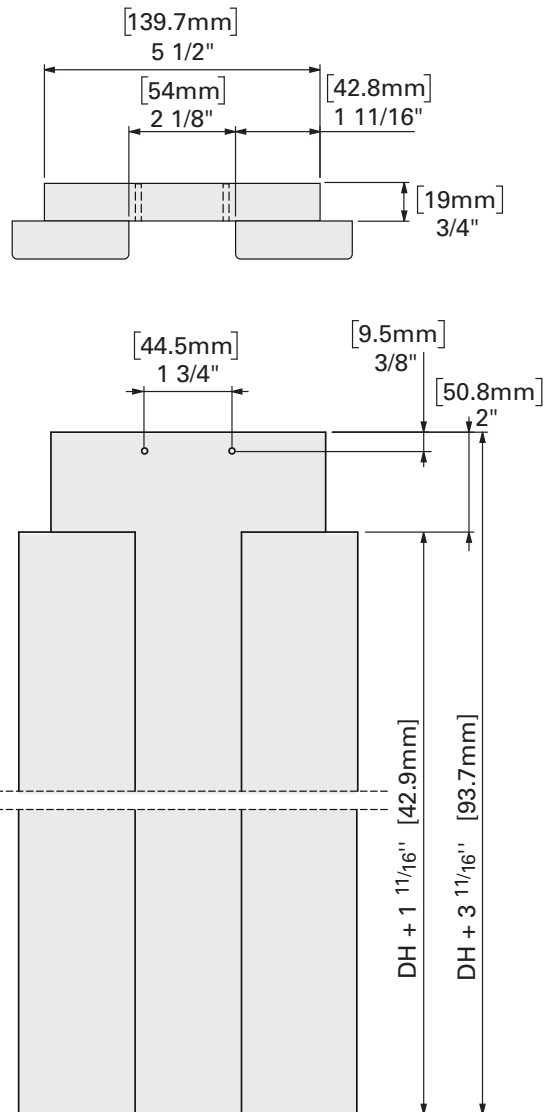

**Door Groove Detail**

1/4" x 13/16"  
6 - 6.5 x 20 - 21mm

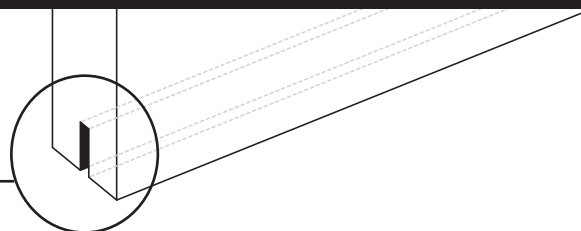

## Mount Plate Positioning

Your Mount Plates:

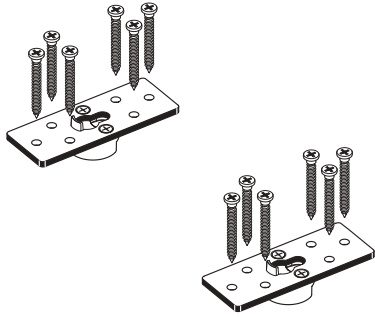

### Single Door Mounting Option 1

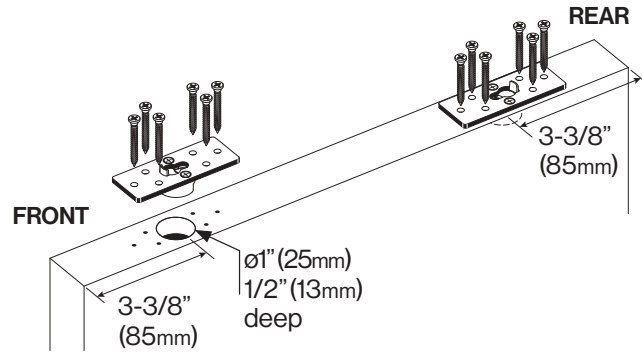

Your Mount Plates:

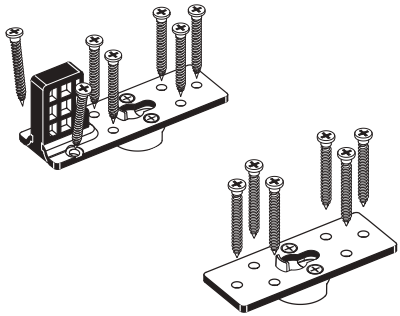

### Single Door Mounting Option 2

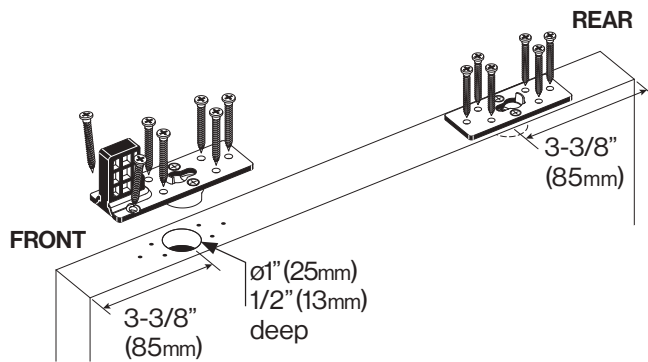

### Bi-Parting (Double Doors)

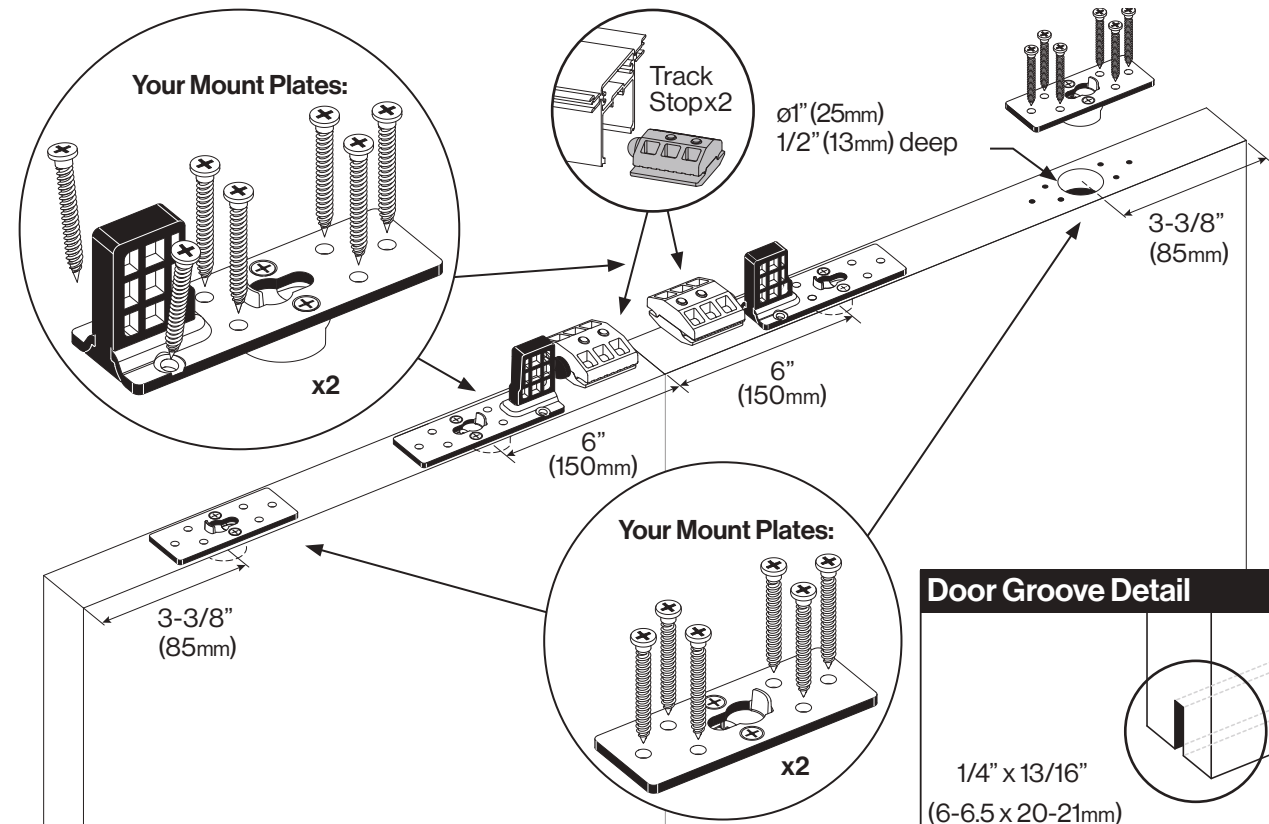

© All copyright and other property in this document is reserved by Cavity Sliders USA Inc. Details and specifications are subject to change without notice. Whilst all care is taken to ensure the accuracy of all information, no responsibility will be accepted for any errors or omissions. Drawings are not to scale.  
CSCAVITY SLIDER™ (O.D. 2019). ZG00202 - 09.2025